

"Technical requirements of refractory materials for burner tile applications - the advantage of a phosphate binder system".

Jens Decker, Tom Atkins, David Mintz – Stellar Materials, Boca Raton, USA
Karel Hoeksma, Roy Ovink – Corus Research, IJmuiden, The Netherlands

1. Introduction

Major industrial processes require combustion in different forms. The burner is the device that is used to combust fuels with an oxidizer and to control the heat transfer into a furnace in which these processes take place. An essential part of a burner is the refractory burner tile either made of ceramic fiber or refractory pre-fabricated shapes.

A burner tile is a complex functional refractory product and inaccurate operation can cause downtime costs which exceeds the costs for the burner equipment by far. Environmental aspects and more stringent regulations have changed the philosophy of burner design in the last 20 years. Burner design is now a compromise between efficient mixing of fuel and oxidizer and the necessity to reduce the total fuel consumption and pollutant emissions, which requires moderate low flame temperatures in order to reduce NO_x. These designs have led to the development of tailor made solutions for certain applications and to highly sophisticated burner designs with tiles of complex shapes. (**Picture 1**).

This paper discusses the technical requirements of refractory materials for burner tile applications and evaluation methods in order to generate thermo- mechanical data as an engineering tool for the design of burner tiles. Furthermore the influence of two different binder systems will be described in this context.

2. Burner Tile Design

The design of a burner tile plays an important role in the performance of a burner. The tile

- forms the desired flame pattern
- avoids flame radiation towards the burner casing
- forms the orifice that controls the flow of air for the combustion reaction
- stabilizes the flame due to the thermal insulating properties of the refractory material

Regarding the burner design, the combustion engineer has to consider the characteristic of the ceramic burner tile material in order to obtain stable combustion process conditions.

The main design problems are:

- The tile is restrained against complete, free, thermal expansion by the external structural steel casing or anchoring. The designer has to consider the physical characteristics of the refractory material by definition of the thermal restraint stresses.
- Sharp inside 90°edges lead to material stress peaks in service.
- The wall thickness of the burner tile is not uniform under isotherm conditions and stresses may concentrate in the thinner areas. Hence critical internal strain controlled loads can occur.

- The design of the tile must be in accordance with the occurring temperature range and the plastic / elastic response of the refractory material within this range.
- Part of the tile is cooled by the fuel and oxidizer, another part is heated by the flame and the furnace. As a consequence the tile has to cope with large temperature differences. In many burners this may be over 1000C.
- In case the burner is stopped and the furnace is hot, then the tile will heat-up quickly and damage caused by thermo-shock is often observed.

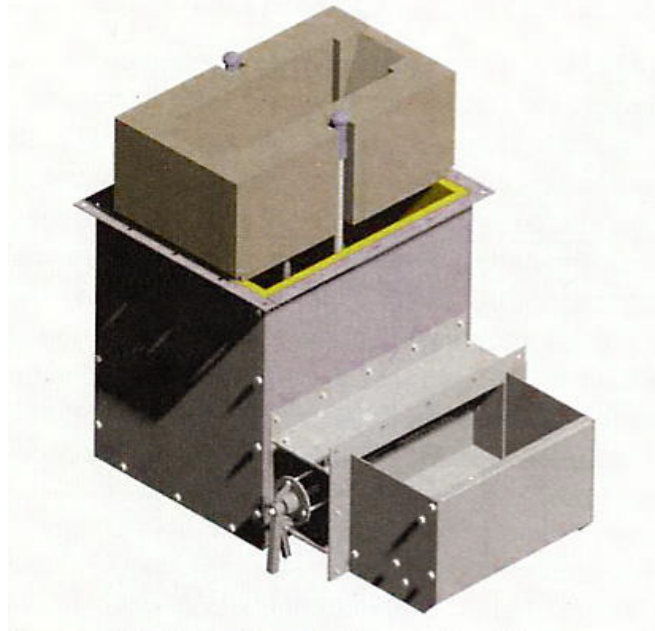

Picture1.) Flat Flame Burner (courtesy of John Zink Company)

Picture 1.0 shows a low emission flat flame burner of complicated tile shape with sharp edges and additional fuel jets in order to reduce NO_x . The purpose of the geometry is to control a precise oxidizing process of the fuel (1) The wall thickness is not uniform and the jets probably keep parts of the tile cold. This is an example for a burner with a critical tile design.

3. Specific evaluation and testing criteria of refractory materials for burner tiles.

3.1. Burner tile temperature

Essential for the material choice and design of the burner tile is the knowledge of the temperature profile in operation. Reliable data can be obtained by experiments. Experiments however are time consuming and dependent on the availability of appropriate equipment.

In addition thermal boundary conditions used for the finite element model are estimated and based on the flame temperature. However, adiabatic flame temperatures are not useful data to estimate the resulting tile temperature. For example in the hydrocarbon and petrochemical industry most burners are working with excess air. Additional cooling of the tiles occurs in low NO_x burners because introduction of inert flue gases into the combustion zone of the burner reduces the peak flame temperature and NO_x formation.

3.3. Thermomechanical Considerations

During high temperature service, burner tiles are required to conduct heat and they may be subjected to rapid temperature variations. This takes place during adjustments of the burner, fuel changes and shut down conditions when cooling down and heating up the burner again. The non-linear temperature gradient during rapid heat up and cool down develops thermal stresses or thermal expansion forces that may fracture the refractory. The refractory structure should resist tensile and compressive strains through a wide temperature range from a rigid solid state at low temperatures to a more viscous state at high temperatures. Cracking from these stresses can have an impact on the flame pattern and in a worst case scenario cause the flame to be in contact with the tile causing problems like hot spots and total destruction of the tile and burner casing.(2)

One approach to determine the resistance of a refractory material against cracking in service is the evaluation of different stress parameters. The expressions obtained from the calculation of the stress parameter R1 – R3 can be transformed in terms of the maximum temperature difference, heat flux or temperature gradient to which the refractory can be subjected without exceeding the thermal stress failure. The “Hasselmann thermal stress resistance parameters R1-R3” are a tool to predict thermal stresses in materials of brittle - elastic behavior for the purpose of basic materials ranking (3).

$$R1 = \sigma (1 - \mu) / (\alpha E)$$

A rapid thermal shock leads to thermal gradient on the surface of a material. R1 is the maximum allowable temperature difference in body under conditions of steady heat flow. (ΔT in °K)

$$R2 = R1 \lambda$$

Considering a constant heat transfer on the surface - R2 is the maximum allowable heat flux through body under conditions of steady heat flow (W/m)

$$R3 = R1 a$$

R3 is the maximum allowable rate of surface heating.

σ = tensile strengths

μ = Poisson ratio (transversal contraction index)

α = linear thermal expansion

E = Young's modulus (static: determined as V-modulus)

λ = thermal conductivity

$a = \lambda / (c_p \rho) =$ thermal diffusivity

Based on the stress parameter, an ideal thermal shock resistant material should possess the following thermo-mechanical properties:

- low thermal expansion
- high thermal conductivity
- high strengths under consideration of the stress/strain relationship. (A high σ/E ratio leads to good thermal shock properties)

Furthermore the tile design is important:

- the wall thickness should be uniform and reasonably thin

- the overall dimensions of the tile or pieces of the tile should be small
- the geometry of the tile should avoid sharp angular shapes

4.0 Material choice for burner tile application.

Castable materials have been traditionally used for burner tiles because of the advantage in minimizing costs when manufacturing complex shapes of limited quantities. Placement of castables, when compared to pressed- or rammed products, is easier and the bodies show a more isotropic structure which is advantageous in relation to thermal shock properties.

One difference between fired products and castable refractories is the higher shrinkage of castables at elevated temperatures which affects the geometry of the body at service temperature. Thus the interaction between permanent linear change and thermal expansion needs to be considered as an important factor for the design of burner tiles.

4.1 Cement bonded materials

In the past 30 years cement bonded materials have evolved from high cement conventional formulations to low and ultra low cement materials with an improvement in placement properties and high temperature stability.

This evolution has been assisted by the development of additives and fillers in order to achieve water reduction to decrease porosity and increase mechanical strengths (4)

4.1.1 Binder characteristic and thermomechanical properties of cement bonded castables.

The binder characteristic of calcium aluminate bonded castable materials has been clearly explained by numerous authors.(5,6,7,8) A simplification of the complex setting procedure can be explained as follows:

High alumina cement (CA, CA₂, C₁₂A₇ etc.) + additives + water → calcium aluminate hydrates (CAH₁₀, C₃AH₆, C₂AH₈, etc.) + additives + water + heat + residual water. (9)

Due to the high quantity of water and the low permeability of cement bonded materials, a rapid temperature increase may result in explosive spalling or steam explosion. Factors that can contribute to explosive spalling include curing conditions, heating and dry-out method, and physical properties of the material (10). Due to these factors pre-cast burner tiles require accurate dry out or pre-firing before the installation.

Usually thermo-mechanical data of cement bonded materials includes refractoriness under load or hot modulus of rupture data. However, compressive stress/strain data of castable materials which are necessary to predict strain controlled loads are not often published.

C.A. Schacht reported that the chemistry of the refractory material has a significant influence on the stiffness of the castable. The lower the cement content and the higher the alumina content the higher the stiffness.(11) Due to the high strength of the low-cement castables the maximum strain is similar to conventional castables

4.2 Phosphate bonded materials

Experience has shown that phosphate bonded burner tiles of complicated shapes can hold up, in some critical process conditions, much better than conventional burner tiles made of cement bonded materials. Since not all phosphate bonded castable materials

possess comparable properties it is important to refer to the distinguishing characteristics.

4.2.1 Binder Characteristic and thermo-mechanical properties

Phosphate bonded refractory castable products are available with various binder systems which can be differentiated as follows:

- heat setting
- cold setting + setting additive
- one component dry material with water addition
- two component mix with phosphoric acid solution or monoaluminium phosphate solution + dry component

The chemical compositions of cold setting phosphate bonded castables are based on the system $Al_2O_3-SiO_2-P_2O_5-M_xO$ (M_xO is alkali- or alkali earth oxide). Heat setting phosphate bonded castables are based on the system $Al_2O_3-SiO_2-P_2O_5$. The P_2O_5 content ranges from approximately 3% – 6% and the M_xO content from approximately 0.5% - 6%.

A great number of works have been reported about the reaction between alumina and phosphoric acid (12,13,14) Alumina reacts with phosphoric acid above 127°C (260°F) to aluminium phosphate and shows considerable strengths above 350°C (660°F). The most often applied phosphate binder in the refractory industry is mono-aluminium phosphate (MAP) in liquid or spray-dried form.

If setting properties at ambient temperature are desired an additional setting agent is needed. This can be an alkali- or alkali earth metal oxide component (M_xO) like sodium, magnesia, calcium or compounds thereof.

The disadvantage of a spray dried MAP additive in a single component material is the poor shelf life due to the strong hygroscopic behavior. Alternatively, phosphoric acid can be used as a liquid in a two component product. Depending on the reactivity both MAP and phosphoric acid need to be diluted to slow down the exothermic reactions.

Phosphoric acid is a tri-basic acid and reacts with different metal oxides to form salts. Some of these salts function as a refractory binder. In an aqueous solution the phosphoric acid reacts in three stages according the molar ratio M_xO / P_2O_5 of 1:1, 2:1 or 3:1.

Table 2 shows as an example the reactions between magnesia and phosphoric acid and the resulting three different stages. Magnesia and magnesium hydroxide are widely used as setting additives for phosphate containing formulations. The reaction type 1 and type 2 are exothermic. However, reaction 1 is much stronger than 2 whereas reaction 3 doesn't show cold setting properties.

Table 2.

1.) Formation of mono- phosphate:	$MgO + 2 H_3PO_4 = Mg (H_2PO_4)_2 + H_2O$
2.) Formation of di- phosphate:	$Mg(H_2PO_4)_2 + MgO = 2 MgHPO_4 + H_2O$
3.) Formation of tri- phosphate	$2MgHPO_4 + MgO = Mg_3(PO_4)_2 + H_2O$

The phosphates being formed at ambient show dehydration of chemically bonded water at elevated temperatures. This condensation process is described in **Table 3**.

Table 3.

1a.) $Mg(H_2PO_4)_2$	= $Mg(PO_3)_2$ Mg- metaphosphate + H_2O	150°C (302°F)
2a.) $2 MgHPO_4$	= $Mg_2P_2O_7$ Mg- phyrophosphate + H_2O	213°C (415°F)
3a.) $Mg_3(PO_4)_2$	= $Mg_3(PO_4)_2$ Mg- orthophosphate	700°C (1292°F)

Phosphate bonded products with a binder system of a two component mono- and a single component di- phosphate are commercially available. The advantage of a two component mono- phosphate bond is the faster setting and faster heat up time. Flame impingement experiments with both kinds of materials have shown that mono-phosphates are less susceptible to explosive spalling than di- phosphate bonded materials.

Possible explanations for this are:

- The mono-phosphate formation is highly exothermic, which cause dehydration during setting.
- The quantity of chemically combined water in the mono- phosphate is higher than in di- phosphates. This can have an influence on the steam pressure in the capillary system of the material during bake out.
- The water in mono-phosphate evaporates at 150 C with max 5 bar steam pressure. For di- phosphate the water is released at 213 C and the steam pressure of 20 bars may exceed the strength of the material.
- Two component products use a molar excess of H_3PO_4 compared to M_xO . The vapor pressure of phosphoric acid and monoaluminium-phosphate solutions are lower than water. Thus, they are less explosive than other (water containing) castable refractories during heat up (15)

It should be noted that the whole dehydration process of phosphate bonded castable refractories hasn't been properly evaluated yet.

The thermo-mechanical properties of phosphate bonded materials are different than those with a cement bond. After setting, additional curing time is not needed. Poly- and meta -phosphate compounds formed during condensation possess a ring and chain structure with a stability up to 800 °C (1500 °F). (16) This flexible structure leads to a low modulus of elasticity and contributes to the thermal shock and abrasion resistance.

Above 900 °C (1650°F) first melting of the M_xO - phosphate compounds of the binder system occurs. Depending on the raw materials, heat setting phosphate bonded materials behave similar because of a reaction of phosphates with M_xO impurities. Thus, phosphate bonded castables with alkali additions can show lower hot modulus of rupture and refractoriness under load numbers compared to cement formulations. Depending on the quantity and kind of alkali additive, this melt phase is of a temporary nature and further reacts with alumina to melts of higher viscosity. In many burner tile applications a certain quantity of melt phase at service temperature reduces the stiffness of the material and improves the thermal shock properties, which is desired.

Between 900 °C (1650°F) and 1600 °C (2900°F) amorphous phosphates and phosphate melts are being formed. Depending on the kind of M_xO - phosphate and quantity thereof, occurring melts can attack the aggregates of the raw materials at process temperatures above 1350 °C (2460°F). Resulting volume changes are due to the formation of

additional melt (shrinkage) or formation of new compounds like Mg-spinel and mullite (expansion). Above 1600 °C (2900 °F) aluminium-phosphate starts to decompose to aluminium-oxide and P₂O₅ which is volatile at this stage.

4.3 Material testing of phosphate bonded materials

As aforementioned cold setting phosphate bonded materials with M_xO- phosphates as a binder component show partial melting at temperatures between 900 °C (1650 °F) and 1400 °C (2550 °F) **Table 4** shows some alkali- and alkali earth metal oxides used as a setting agent.

Table 4. Melting points of alkali phosphates (17)

Chemical formula	Name	Melting Point °C (°F)
Na ₄ P ₂ O ₇	Na pyrophosphate	985 (1805)
K ₄ P ₂ O ₇	K pyrophosphate	1109 (2030)
Ca (PO ₃) ₂	Ca metaphosphate	975 (1790)
Ca ₂ P ₂ O ₇	Ca pyrophosphate	1350 (2460)
Mg(PO ₃) ₂	Mg metaphosphate	1165 (2130)
Mg ₂ P ₂ O ₇	Mg pyrophosphate	1383 (2520)
Al (PO ₃) ₂	Al metaphosphate	1060 (1940)

There is some evidence that occurring phosphate melts are temporary in nature and change at increased temperatures to different compounds. Some test methods, however, do not reflect this materials characteristic. Critical tests are:

- Thermal expansion under load > 1100 °C (2000 °F).
- Hot modulus of rupture > 1100 °C (2000 °F)
- Refractoriness under load

The results obtained from these tests can be significantly influenced by the occurring melt phase at test temperature. For instance samples pre fired at 1100 °C (2000 °F) with a holding time of 24 hours showed 10% HotMOR increase and with a holding time of 168 hours an increase of 65% at 1100 °C (2000 °F). Typically, published data references test results after only a five hour holding time.

Another example is thermal expansion under load. Due to the load, plastic flow and the coefficient of thermal expansion are mixed and resulting high permanent linear change is then overstated.

The next example shows the conversion from calcium phosphate to Anorthit.

This reaction is evident from XRD analysis. Calcium-monophosphate as part of the binder component is being formed at ambient temperatures by the reaction of phosphoric acid and calcium oxide. During heat up this monophosphate converts into calcium - metaphosphate as shown in **Table 3**. Calcium metaphosphate has a melting point of 975 °C (1800 °F).

After firing at 1600 °C (2900 °F) with 10hours holding time the XRD diagram (**Figure 1**) shows that all phosphate has been converted to AlPO₄. Calcium oxide on the other hand has been reacted with mullite and converted into Anorthite with a melting point of 1550 °C (2800 °F)

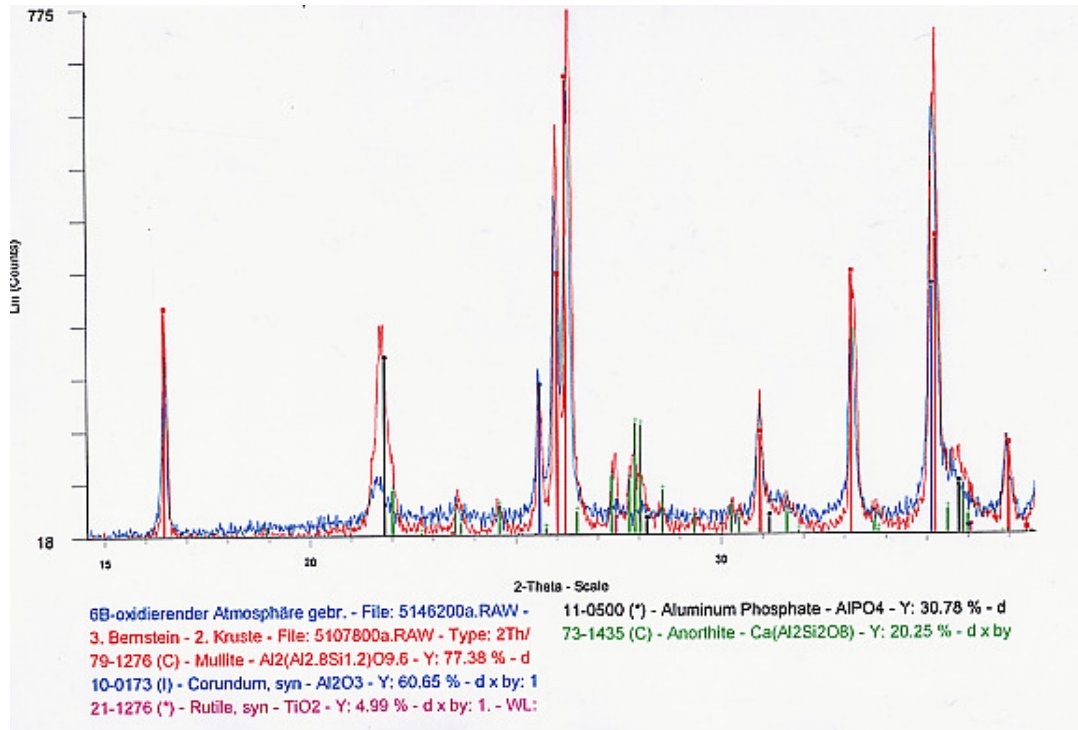

Figure 1 XRD analysis Formula 6B – 1600 C/10h (2900 °F)

Test procedures of phosphate bonded materials should report this operational characteristic since burner tiles are exposed to elevated temperatures with holding times up many years. Otherwise a material assessment based on standard test procedures would lead to the wrong conclusion.

5. Numerical studies

Comparative FEM analysis of two burner tiles made of commercially available cement bonded- and phosphate bonded castables have been conducted in order to determine the thermo-mechanical behavior of the different materials during the critical heat up. The tile used for the modeling is a burner tile of an annealing furnace.

A heat up was considered on this axi-symmetric burner tile as indicated in **Figure 2**. The thermal boundary conditions are indicated in **Figure 3**. A heat up time of 48 hours was considered.

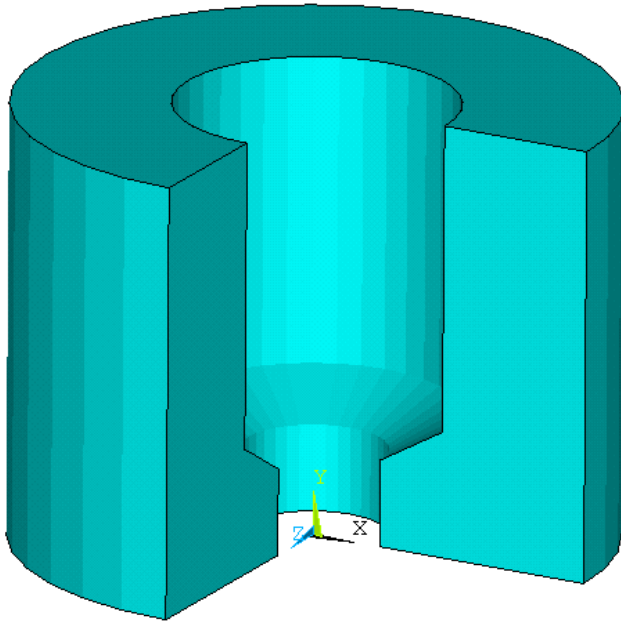

Figure 2 The axis-symmetric burner geometry.

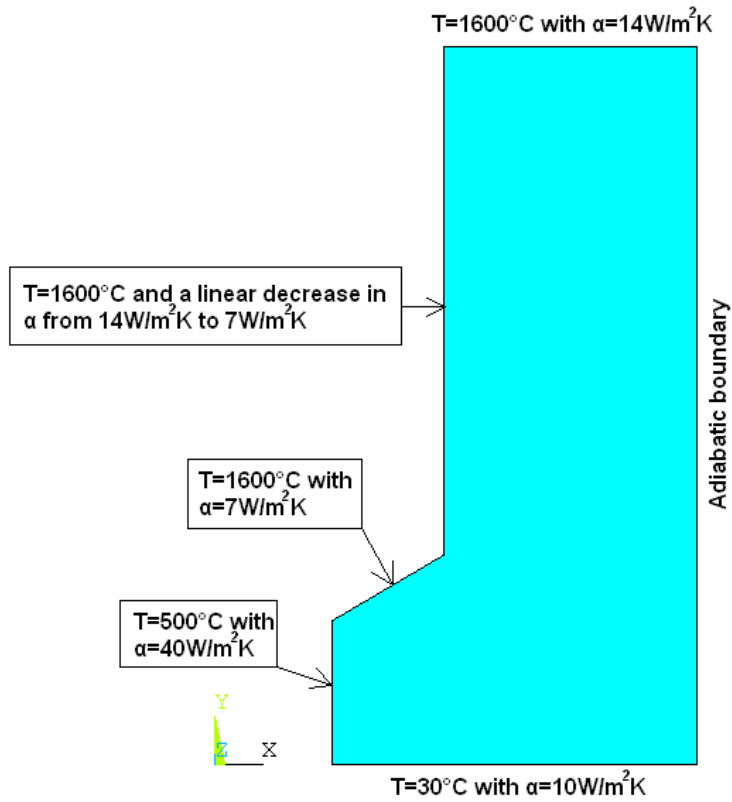

Figure 3 Thermal boundary conditions used in the finite element model

5.1 Properties of test materials

The material properties used in the simulation are those for cement bonded castable “HS” and phosphate bonded castable “SB” and are summarized in **Table 5**.

The cement bonded material is an andalusite based LCC which had been supplied by the manufacturer in a dried “ready to install” state.

The phosphate bonded material is a mullite based two component mono-phosphate castable as shown by reaction 1, Table 2, with 61% alumina and 4.5% P₂O₅ content.

The yield stress under tensile loading conditions is taken to be temperature dependent and is summarized in **Table 6** and **7**. The yield stress under compressive loading is assumed to be a factor of 10 higher.

Table 5 Material properties of test material

	Andalusite HS	Phosphate Bonded SB
Density	2450 kg/m ³	2360 kg/m ³
Thermal expansion	6.6e-6 K ⁻¹	5.5e-6 K ⁻¹
Thermal conductivity	1.4 W/mK	1.7 W/mK
Specific heat	1000 J/kgK	1015 J/kgK
Poisson's ratio	0.3	0.3

Table 6. The temperature dependent yield stress under tensile loading conditions for LCC Andalusite HS.

Temperature (°C)	Yield stress (MPa)	Strain (10 ⁻³)	V- modulus (N/mm ²)
20 (70°F)	14	0.5	28 000
400 (750°F)	15	0.7	21 428
800 (1500°F)	16	0.8	20 000
1000 (1800°F)	18	2.5	7 200
1200 (2200°F)	11	13.8	797

Table 7 The temperature dependent yield stress under tensile loading conditions for Phosphate bonded SB

Temperature (°C)	Yield stress (MPa)	Strain (10 ⁻³)	V- modulus (N/mm ²)
200 (70°F)	5.7	0.6	9618
600 (1100°F)	11.1	1.2	9502
800 (1500°F)	7.9	0.8	10368
1100 (2000°F)	5.1	1.4	3596

6 Results

6.1 FEM Analysis for the Andalusite HS burner tile

From the simulations it turned out that most of the damage occurred within the first hour of heat up. **Figure 4** gives the calculated temperature contours after one hour of heat-up. Calculated displacements have been scaled by a factor of 50 so that one can clearly see the trumpet like shape of the burner block. Highest stresses occur in circumferential direction. **Figure 5** gives the calculated stresses in the circumferential direction.

Calculated stresses are close to the yield stress limit for much of the outer burner block region. The calculated plastic deformation depicted in **Figure 6** indicates where cracks are most likely to be initiated. Notice that crack deformation in reality may be more severe because of the brittle nature of ceramics in which the calculated regions with plastic deformation fail to carry any normal stresses.

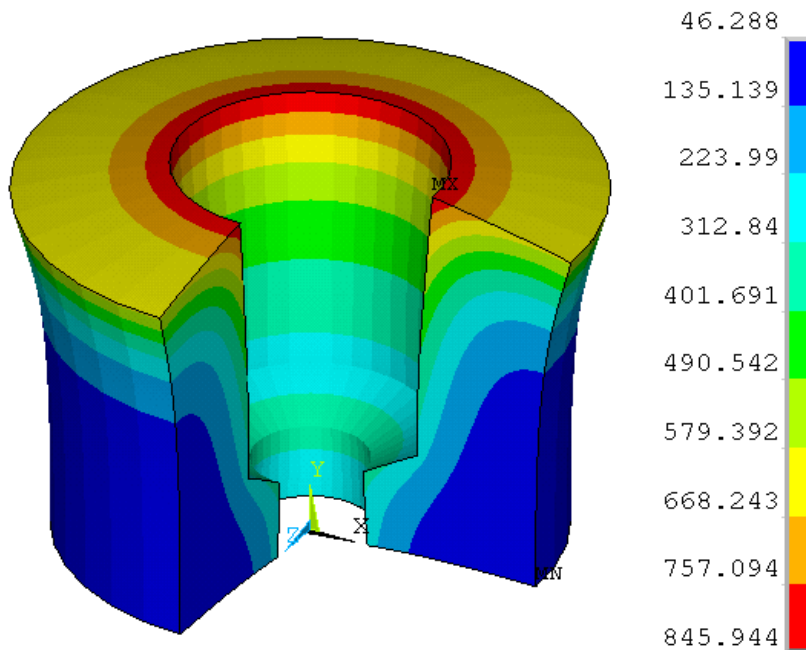

Figure 4 Temperature contours after one hour of heat up (°K). A displacement-scaling factor of 50 was used.

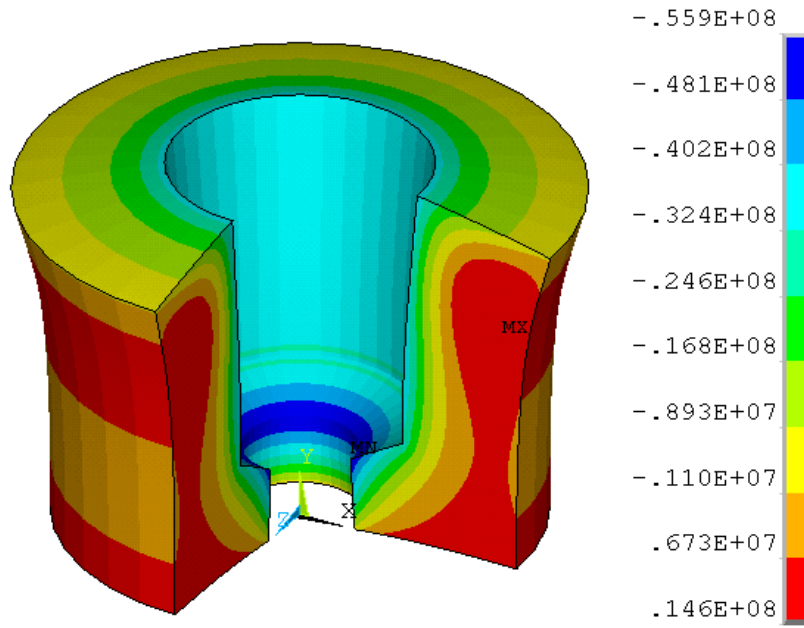

Figure 5 Calculated stresses in circumferential direction (Pa)

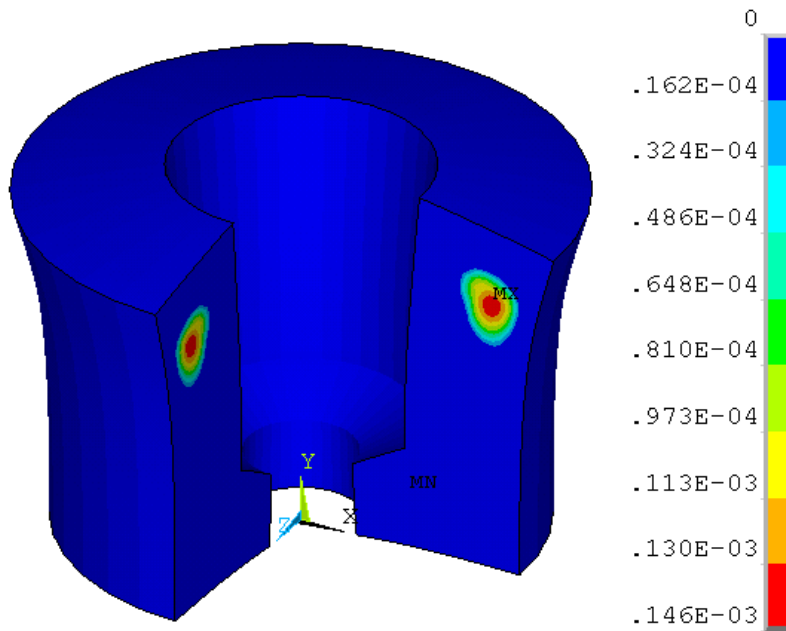

Figure 6 Calculated plastic strain in circumferential direction (non reversible strain, Epsilon)

6. 2 FEM analysis for the Phosphate bonded SB

From this simulation it turned out that no damage occurred within the first hour of heat up. **Figure 7** shows the calculated temperature profile after one hour of heat-up. **Figure 8** gives the calculated stresses in the circumferential direction. Compared to **Figure 5** the stresses are lower than the yield stress stated in table 6.

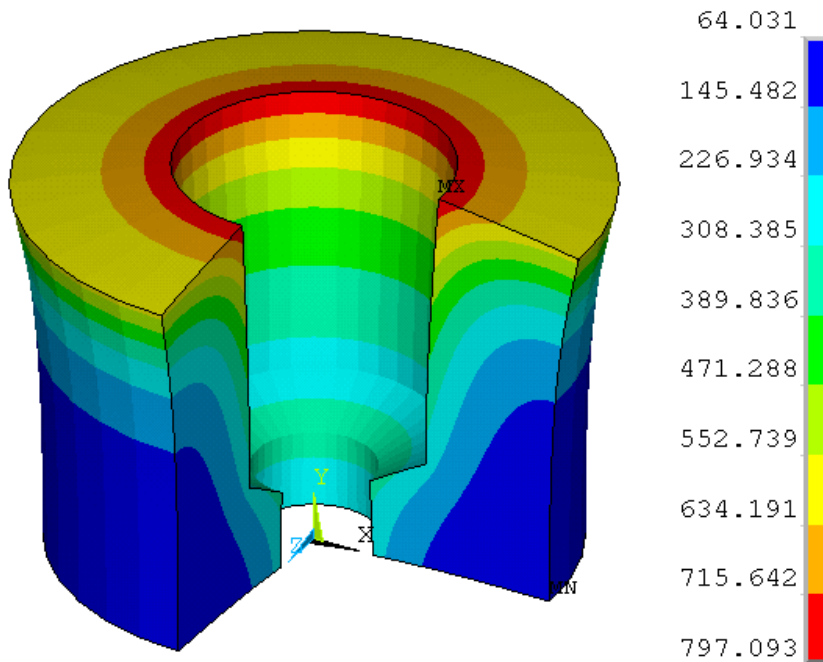

Figure 7 Temperature contours after one hour of heat up. A displacement-scaling factor of 50 was used.

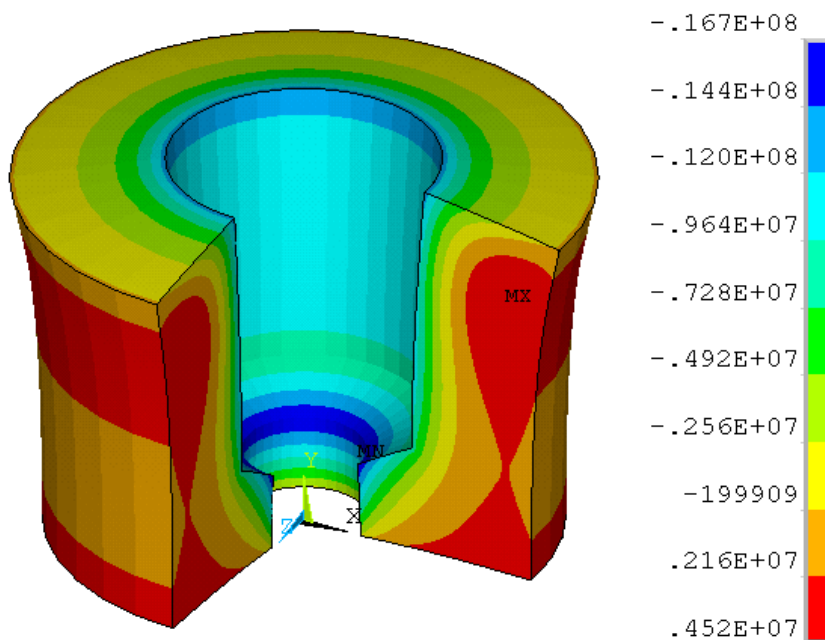

Figure 8 Calculated stresses in circumferential direction.

6.3 Calculation of Hasselmann parameter

The calculations of the “Hasselmann thermal stress resistance parameters R1-R3” are shown in **Table 8** and **9**.

In the critical temperature range up to 850 °C (1560 °F) R1, R2 and R3 of Phosphate bonded SB shows better numbers compared to Andalusite HS. Basically this is a confirmation of the results from FEM analysis and means the phosphate bonded material allows a higher temperature change; heat flux and temperature increase at the surface without exceeding the failure stress compared to the cement bonded material. However, a material ranking based on these results is difficult because above 1100 °C (2000 °F) both materials form melted phases and show plastic behavior. Hasselmann assumes only elastic properties.

Hence the quality of a material choice based on thermal stress resistance parameter calculations would increase with the data base and comparative FEM analysis.

Table 8 Stress parameter of Phosphate bonded SB

Temperature (°C)	R1 (°C)	R2 (W/m)	R3 (m ² °K/s)
200 (390°F)	75	128	5,34 e-5
600 (1100°F)	149	253	9,16 e-5
800 (1500°F)	97	175	5,89 e-5
1100 (2000°F)	178	378	12,10 e-5

Table 9 Stress parameter of Andalusite HS

Temperature (°C)	R1 (°C)	R2 (W/m)	R3 (m ² °K/s)
20 (70°F)	54	75	3,1 e-5
400 (750°F)	74	103	4,2 e-5
800 (1500°F)	84	117	4,7 e-5
1000 (1800°F)	268	375	15,3 e-5
1200 (2200°F)	1453	2034	82,9 e-5

Conclusion

Comparative FEM analysis of a burner tile made of low cement bonded andalusite and a phosphate bonded castable have been conducted.

Under given thermal boundary conditions it is likely that the cement bonded material would show cracking because the calculated stresses (**Figure 5**) are close to the yield stress limit (**Table 6**). It can be concluded that improved properties can be achieved by using a cement bonded castable of higher cement content in order to lower the stiffness in this temperature range.

The results of the phosphate bonded material "SB" show a lower V-modulus, higher thermal conductivity and a lower coefficient of thermal expansion compared to the low cement bonded andalusite material. The determining low V- modulus is characteristic for phosphate bonded material and can be explained with the formation of poly- and meta - phosphate compounds during the condensation process which leads to flexible ring- and chain structure with a stability up to 800 °C (1500 °F).

Due to this and the properties explained under **4.2.1** mono-phosphate bonded materials do not require dry-out and therefore it is possible to manufacture burner tiles "just in time" with an installation right after setting.

Although this FEM analysis is only focused on the heat up process of the tile it shows the material behavior at a very critical state of the temperature cycle. This is confirmed by calculations of the thermal stress resistance parameters R1-R3 which show different results of the two test materials in this temperature range.

Both FEM analysis and the calculation of stress parameter are practicable tools for materials ranking. A ranking based on stress parameter calculations however depends on a comprehensive data base. Traditional material testing procedures have shown to be inaccurate predictors of the performance of phosphate bonded materials in this application. One has to consider that tests under load conditions show results which are probably influenced by temporary melt phases with lower viscosity and plastic flow. Therefore it is recommended to compare results achieved by using varied and extended holding times.

- 1.) Baukal C.E., "The John Zink Combustion Handbook," pp 303. 2001
- 2.) Schacht C.A., "Thermomechanical Behavior of Refractories" in: "Key Engineering Materials", Vol.88. 1993 pp 204-206
- 3.) Hasselmann D.P.H., "Thermal Stress Resistance parameters for brittle refractory ceramics," Bulletin of the Amer. Ceram. Soc. 49. 1970. pp 1033 - 1037
- 4.) Parr C., Bier T.A., Bunt N.C., Spreafico E.E., "Calcium Aluminate Cement based castables for demanding applications," Lafarge Technical Paper
- 5.) Parr C., Bier T.A., Mathieu A., Spreafico E.E., "Calcium aluminate cements for monolithic refractories," Proceedings of the 1 Monolithic Conference, Teheran, Iran; 1997
- 6.) Petzold, Ulbricht, "Feuerbeton und betonartige feuerfeste Massen und Materialien,". Deutscher Verlag fuer Grundstoffindustrie, Leipzig. pp40- 41
- 7.) Schulle W. "Feuerfeste Werkstoffe," Deutscher Verlag fuer Grundstoffindustrie, Leipzig. pp352 – 357
- 8.) Plibrico Japan, "Technology of Monolithic Refractories,". 1999. pp148 – 164
- 9.) Krebs R. "Unshaped Refractory Materials," 1997. pp193 in: Routschka G. "Refractory Materials." 1997. pp 193
- 10.) Plibrico Japan, "Technology of Monolithic Refractories." 1999. pp225 - 225
- 11.) Schacht. Charles A., "Refractory Linings". New York 1995. pp 157 - 192
- 12.) F.J Gonzales, J.W Halloran "Reaction of Orthophosphoric- Acid with Several Forms of Aluminum Oxide," Amer. Ceram. Bulletin Vol. 59 No.7, 1980. pp 727
- 13.)Bartha P., Lehmann H., Koltermann M., "Untersuchungen zur Bindung keramischer Werkstoffe mit H3PO4", Ber. Dt. Keram. Ges. 48 (1971) H3. pp111
- 14.) Bothe J.V., Brown P.W., "Reactivity of Aluminatowards Phosphoric Acid", J. Am Ceram Soc. 76 (9) pp 2353-58 (1993)
- 15.) Plibrico Japan, "Technology of Monolithic Refractories," 1999. pp 237
- 16.) Appelt R., "Aluminiumoxid und seine Bindung mit Monoaluminiumphosphat," Sprechsaal, Vol.116, No.9, 1983
- 17.) Plibrico Japan, "Technology of Monolithic Refractories," 1999. pp 175